

GSM Architecture & Channels: Review Study

Shivinder Devra¹, Arsh Sharma²

¹Department of Electronics Technology, GNDU, Amritsar

²Department of Electronics Technology, GNDU, Amritsar

¹shivinder_gndu@yahoo.com

²arshsharma25@gmail.com

Abstract— GSM, the Global System for Mobile communications, is a digital cellular communications system that has rapidly gained acceptance and market share worldwide. In addition to digital transmission, GSM comprises many advanced services and features, including ISDN compatibility and worldwide roaming in other GSM networks. GSM architecture is a combination of three subsystems: Base Station Subsystem(BSS), Network Switching Subsystem (NSS) & Operation Support Subsystem (OSS). BSS consists of Base Transceiver System (BTS) and Base System Controller (BSC) which connects with Mobile Station (MS). NSS consists of MSC which connects with BSC. OSS maintains BSS and NSS. GSM channels are responsible for connecting two MS's. It consists of two channels: Traffic Channels (TCH) which make data flow between two MS's possible and Control Channels (CCH) which supervises the signalling and synchronization between the base station and mobile station. This paper will give an overview of GSM system architecture & its channels.

Keywords— GSM architecture, Base Station Subsystem(BSS), Network Switch Subsystem(NSS), Operational Subsystem(OSS), GSM channels, Traffic Channels (TCH), Control Channels (CCH)

I. INTRODUCTION

The development of Global System for Mobile Communication (GSM) started in 1982 when the Conference of European Posts and Telegraphs (CEPT) formed a study group called Groupe Spécial Mobile (the initial meaning of GSM) whose aim was to study and develop a pan-European public cellular system in the 900 MHz range [6]. Some of the basic criteria for their proposed system were:

- Good subjective speech quality
- Low terminal and service cost
- Support for international roaming
- Ability to support handheld terminals
- Support for range of new services and facilities
- Spectral efficiency
- ISDN compatibility

Commercial operation of GSM networks started in mid-1991 in European countries. By the beginning of 1995, there were 60 countries with operational or planned GSM networks in Europe, the Middle East, the Far East, Australia, Africa, and South America, with a total of over 5.4 million subscribers. GSM uses a mixture of both Frequency Division Multiple Access (FDMA) and Time Division Multiple Access (TDMA) [2]. FDMA parts include the division by frequency of the 25 MHz bandwidth into 124 carrier frequencies spaced 200 KHz for GSM900. TDMA further divides each carrier frequencies into 8-time slots such that each carrier frequency is shared by 8 users. In GSM, the basic radio resource is a time slot with duration of 577 μ s. 8 Time slots of 577 μ s constitute a 4.615 ms TDMA Frame. GSM uses Gaussian Minimum Shift Keying (GMSK) modulation scheme to transmit information over Air Interface [1]. GSM uses number of channels to carry data over air interface; these channels are broadly divided into following two categories:

- i. Physical Channels
- ii. Logical Channels

This paper is divided into five parts. Starting with an introduction (Section-I), next section covers the need of GSM (Section-II). Moving ahead, GSM architecture is discussed (Section-III). Next section is about the interfaces in between the GSM subsystems (Section-IV). After that GSM channels are discussed (Section-V). This section is about the call origination using GSM channels (Section-VI). Finally, conclusions summarize the last section (Section-VII).

II. NEED OF GSM

Features of GSM that account for its popularity and wide acceptance are listed below:

- i. Improved spectrum efficiency
- ii. International roaming
- iii. Low-cost mobile sets and base stations (BSs)
- iv. High-quality speech



- v. Compatibility with Integrated Services Digital Network (ISDN) and other telephone company services
- vi. Support for new services.

III. ARCHITECTURE

GSM architecture is classified into three subsystems i.e. BSS, NSS, and OSS.

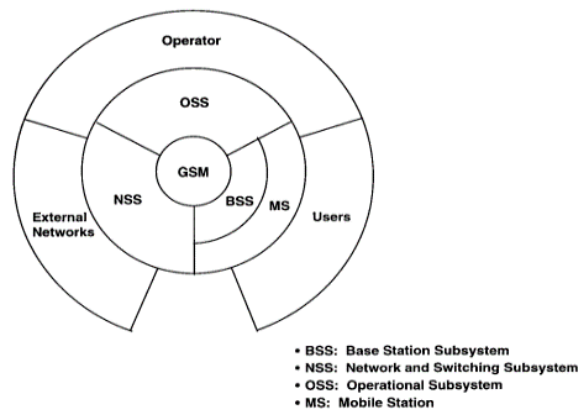

Fig 1: Basic Architecture [2]

The BSS provides and manages communication paths between the MSs and the NSS. It includes management of the radio interface between MSs and the whole GSM system. The NSS has the province of managing communications and linking MSs to the relevant networks or other MS's. Neither NSS is in direct contact with the MSs, nor is the BSS in direct contact with external networks [10], [5]. In the GSM, interaction between the subsystems can be grouped into two main parts:

- i. **Operational:** External networks to or from NSS to or from BSS to or from MS to or from subscriber
- ii. **Control:** OSS to or from service provider

1. GSM Subsystem Entities

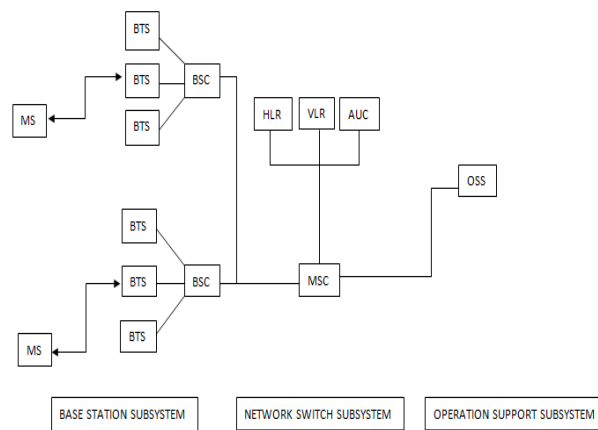

Fig 2: GSM Architecture [10]

a) Mobile Station (MS):

A Mobile Station is used by a mobile subscriber to communicate with the cellular system. GSM MSs consist of:

- i. A mobile terminal
- ii. A Subscriber Identity Module (SIM)

b) Base Station Subsystem (BSS):

BSS is the section which is responsible for handling and signaling traffic between a MS and the NSS [7]. It consists these two devices:



- i. **Base Transceiver System (BTS)** - The BTS is the radio equipment. It handles the radio interface to the mobile station. A group of BTSs is controlled by a BSC.
- ii. **Base Station Controller (BSC)** - The BSC is a high-capacity switch which provides all the control functions and physical links between the MSC and BTS such as handover, cell configuration data, and control of radio frequency (RF) power levels in base transceiver stations. A number of BSCs are served by an MSC.

c) Network Switching Subsystem (NSS):

The NSS main role is to manage the communications between GSM and other network users. Another task of it includes the main switching functions of GSM, databases required for the subscribers, and mobility management.

- i. **Mobile Station Controller (MSC):** The MSC is the central unit of NSS. It performs the telephony switching functions of the system. It controls the traffic among all of the BSCs.
- ii. **Home Location Receiver (HLR):** The HLR is the functional unit used for management of mobile subscribers. The information stored in it are subscriber's identity, location, and authentication. It acts as a permanent store for a person's subscription information until that subscription is canceled.
- iii. **Visitor Location Receiver (VLR):** The VLR is the functional unit which temporarily stores subscription information so that the MSC can service all the subscribers currently visiting that MSC service area. The VLR is regarded as distributed HLR because it holds a copy of the HLR information stored about the subscriber.
- iv. **Authentication Centre (AUC):** The AUC is a database connected to the HLR which provides it with the authentication parameters and ciphering keys used to ensure network security.

d) Operation Support Subsystem (OSS):

The operations and maintenance center (OMC) is connected to all equipment in the switching system and to the BSC. The implementation of OMC is called the operation support system (OSS). The OMC provides a single point for the maintenance personnel to maintain the entire system. One OMC can serve multiple MSCs.

IV. GSM INTERFACES

The interfaces between various elements of the GSM network facilitates the information interchange. It also enables the case that network elements from different manufacturers can be used [2].

- i. **Um interface:** This interface is linking the Mobile Equipment (ME) and the Base Station (BTS/BSC). It exchanges information in air.
- ii. **Abis interface:** This interface is linking the BSC and a BTS, and it has not been totally standardized. It is an internal interface as the BTS and the BSC are both part of the BSS. The Abis interface allows control of the radio equipment and radio frequency allocation in the BTS.
- iii. **A interface:** This interface is linking the BSS and the MSC. This interface carries information to enable the channels, timeslots. The messaging required within the network to enable handover etc. to be undertaken is carried over this interface.
- iv. **B interface:** This interface is linking the MSC and the VLR. It uses a protocol known as the MAP/B protocol, the letter "B" indicating that the protocol is used for "B" interface. This is an internal interface as the VLR is a part of the MSC. The interface is used by the MSC when it needs to access data regarding a MS located in its area [8].
- v. **C interface:** This interface is linking the HLR and the MSC. The protocol used for communication is MAP/C, the letter "C" indicating that the protocol is used for the "C" interface. It helps in communication between the MSC and the HLR regarding various aspects, for example, subscriber information.
- vi. **D interface:** This interface is linking the VLR and the HLR. It uses the MAP/D protocol, the letter "D" indicating that the protocol is used for the "D" interface. It is used to exchange the data related to the location of the Mobile Equipment and to the management of the subscriber.
- vii. **E interface:** This interface is linking two MSCs. The E interface exchanges data related to handover between the two MSCs. It uses the MAP/E protocol, the letter "E" indicating that the protocol is used for the "E" interface.
- viii. **F interface:** This interface is linking the MSC and EIR. It uses the MAP/F protocol, the letter "F" indicating that the protocol is used for the "F" interface. The communications along this interface are used to confirm the status of the International Mobile Equipment Identity (IMEI) of the Mobile Equipment (ME) gaining access to the network [9].
- ix. **H interface:** This interface is linking the MSC and the AUC. It uses the MAP/H protocol, the letter "H" indicating that the protocol is used for the "H" interface. It transfers short messages.

In a system, information flows forward, backward and sideways. This information flow is referred to as communication. Communication channels refer to the way this information flows within the system [1][4].



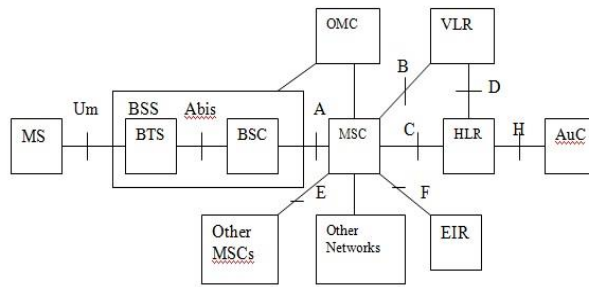

Fig 3: GSM Interfaces [8]

V. GSM CHANNELS

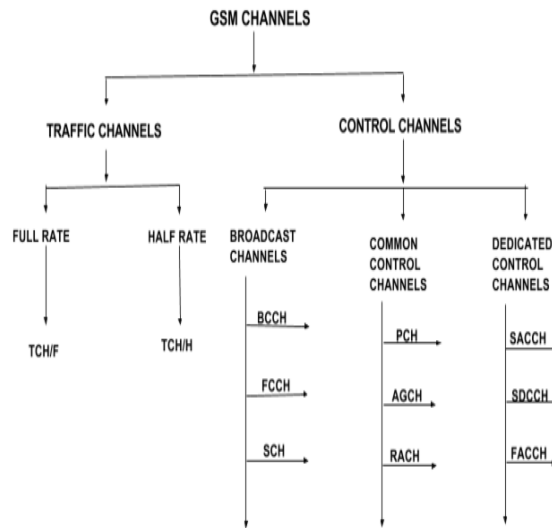
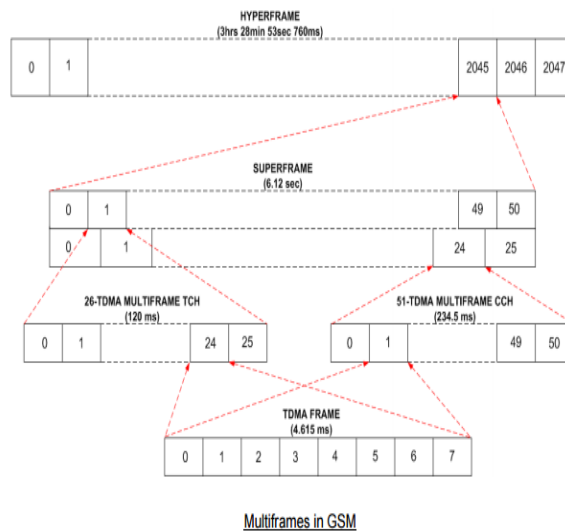

Fig 4: GSM Channels [1]



Multiframes in GSM

Fig 5: Multiframes in GSM [1]

1. Traffic Channels (TCH): This channel carries digitally encoded user’s speech or data and has identical functions and formats on both the forward and reverse link.



a) Full Rate Traffic Channels (TCH\F): This channel carries information at a rate of 22.8 Kbps.

b) Half Rate Traffic Channels (TCH\H): This channel carries information at a rate of 11.4 Kbps.

8 Time Slots (1 Time Slot = 1 Physical Channel) of 577 μ s constitutes a 4.615 ms TDMA Frame. In GSM standard data on a time slot transmitted in bursts, so time slot is often expressed in BP (Burst Period). 1 BP represents 1 TS. TDMA frame (4.615 ms of 8 TS) further structured into Multiframe. There are two types of Multiframe, 26 TDMA Multiframe which consists 26 TDMA frames with duration of 120 ms and used to carry the channels like TCH, SACCH, FACCH etc. and 51 TDMA Multiframe which consists 51 TDMA frames with duration of 234.5 ms and used to carry channels like FCCH, SCH, BCCH, CCCH, SDCCH, SACCH etc. [1], [8]. These Multiframe further structured into superframe and Hyperframe.

- i. **SUPERFRAME:** Superframe consists of 51*26 TDMA frames with a duration of 6.12 sec.
- ii. **HYPERFRAME:** Hyperframe consists 2048 superframes (2048*51*26 TDMA frames) with duration of 3 hrs, 28 min, 53 secs and 760 ms.

2. Control Channels (CCH): This channel carries control information to enable the system to operate correctly. There are three main categories of control channels in GSM which are further divided into several categories:

- i. **Broadcast Channels (BCH):** The broadcast channel operates on the forward link of a specific Absolute Radio Frequency Channel Number (ARFCN) within each cell, and transmits data only in the first time slot (TS0) of certain GSM frames.

a) Broadcast Control Channels (BCCH) – DOWNLINK

This channel broadcasts network and cell specific information required to identify the network and gain access.

b) Frequency Control Channels (FCCH) – DOWNLINK

This channel contains frequency correction bursts which are used by the mobiles for frequency correction. It bears information for frequency synchronization. It allows each subscriber unit to synchronize its internal frequency standard to the exact frequency of the base station.

c) Synchronization Channel (SCH) – DOWNLINK

This channel is used by the MS to learn the Base Station Information Code (BSIC) as well as the TDMA frame number (FN). There are 6 bits of BSIC which have two parts; 3 bits NCC and 3 bits BCC. NCC stands for Network Colour Code and used to identify the BTS for which measurement is made. BCC stands for Base Station Colour Code and used for a better transmission in case of interference [6]. BICS avoids ambiguity or interference.

- ii. **Common Control Channels (CCCH):** This channel is responsible for transferring control information between all mobiles and the BTS. It is necessary for call origination.

a) Paging Channel (PCH) – DOWNLINK

This channel is used for alerting to Mobile Subscribers for incoming calls, SMS, and other mobility services. Every MS in a cell periodically listens to this channel.

b) Random Access Channel (RACH) – UPLINK

This channel is used to send a request to the network for a dedicated resource to the MS. If the request is not granted within a specific time period by the network, the MS repeats the request on the RACH.

c) Access Grant Channel (AGCH) - DOWNLINK

This channel is used by a BTS to notify the MS of the assignment of a dedicated control channel.

iii. Dedicated Control Channels (DCCH):

Like traffic channels, they are bidirectional and have the same format and function on both the forward and reverse links.

a) Standalone Dedicated Control Channel (SDCCH) – UPLINK/DOWNLINK

In response of RACH, the network allocates SDCCH over AGCH for further communication between MS and BTS. This channel is used for the Location Update, Voice Call Setup and SMS.



b) Fast Associated Control Channel (FACCH) – UPLINK/DOWNLINK

This channel is used to convey Handover information. There is no time slot and frame allocation dedicated to this channel. This channel can be associated with SDCCH or TCH and works on the principle of stealing. The burst of TCH is replaced by FACCH signaling when required.

c) Slow Associated Control Channel (SACCH) – UPLINK/DOWNLINK

This channel is always associated with TCH or SDDCH used for control and supervision of signals associated with the traffic channels.

VI. CALL FLOW USING CHANNELS

The call origination made by the Mobile Station (MS) is a multi-step process on the network side. First of all, broadcast channels are already being transmitted by the BTS continuously. When a number is dialed by the MS, Random Access Channels (RACH) is sent to the BSC for allocation of the channel. In response to that Access Grant Channel (AGCH) is sent by BSC as a confirmation. Standalone Dedicated Control Channel (SDCCH) can be used for both downlinks as well as uplink [7]. Hence, it is used for multiple purposes in this flow. It is sent by the MS to MSC with its location update information.

Through SDCCH MSC request for the International Mobile Subscriber Identity (IMSI) number and then this information is sent back to MSC by MS by SDCCH [2]. Along with IMSI to MSC, SDCCH gives location update to HLR and information about equipment to Equipment Identity Register (EIR) which is a part of Authentication Centre (AUC). Using the same channel security and ciphering of call is done. After all, this process connection is established and ringing begins [6]. Also, the Traffic Channel (TCH) is allocated for the call. Hence, the conversation starts between the two MS's.

VII. CONCLUSION

Finally, I am concluding through deep thinking as this is an under developing technology and hence there is a vast field of expansion in the field of wireless communication. Due to this technology, the fundamental ability to communicate will be possible.

In this paper, there is complete information about GSM architecture & its channels. It is based on 2G completely. The study and role of the various components or stages in the GSM architecture is explained in the paper. The flow and control of data between the two MS, uplink, and downlink transfers are also demonstrated in the paper along with the data rate values. In 2G radio signals used are digital. It introduced data services and SMS text messages.

As time passes people need more and more speed. 2G can provide the only speed of 30Kbps. So, 3G has introduced whose speed is 200Kbps. 4G has also been introduced but it is in LTE phase. But, humans don't stop on one thing and research on 5G has been in progress. It will change the cellular communication system completely. The development of the above research is in under the future revolution in the wireless communication system.

REFERENCES

- [1] Theodore S. Rappaport, "Wireless Communication Principles and Practice" Harlow Pearson 2005 Prentice Hall International Series in optoelectronics, second edition.
- [2] Teletopix [Online] <http://www.teletopix.org/category/gsm/>
- [3] G. Gu, G. Peng, "The survey of GSM wireless communication system", Computer and Information Application (ICCIA), 2010 International Conference on, Year: 2010, Pages: 121-124, DOI: 10.1109/ICCIA.2010.6141552
- [4] M. Rahnema, "Overview of the GSM system and protocol architecture", IEEE Communications Magazine, Year: 1993, Volume: 31, Issue: 4, Pages: 92-100, DOI: 10.1109/35.210402
- [5] P.L. Reilly, "GSM network architecture issues for the next century", Vehicular Technology Conference, 1994 IEEE 44th, Year: 1994, Pages: 325-329 vol.1, DOI: 10.1109/VETEC.1994.345111
- [6] Tutorials Point [Online] www.tutorialspoint.com/gsm
- [7] B. Mallinder, "An overview of the GSM system, "Proc. Nordic Seminar on Digital Band Mobile Radio Commun.", pp.12-15, Sept. 1988
- [8] Jay Jayapalan and Mike Burke, "Cellular Data services architecture and signaling", IEEE personal communication, second quarter", pp.44-55, 1994.
- [9] Khalid Al-Tawil, Ali Akarami, Habib Youssef. "A New Authentication Protocol for GSM Networks". In IEEE 23rd Annual Conference on Local Computer Networks(LCN'98) (pp.21-30).
- [10] Michel Mouly & Marie-Bernadette Paulet, The GSM System for Mobile System

